

# Manual

---

## 10" Sliding Table Saw

MODEL MJ2325A

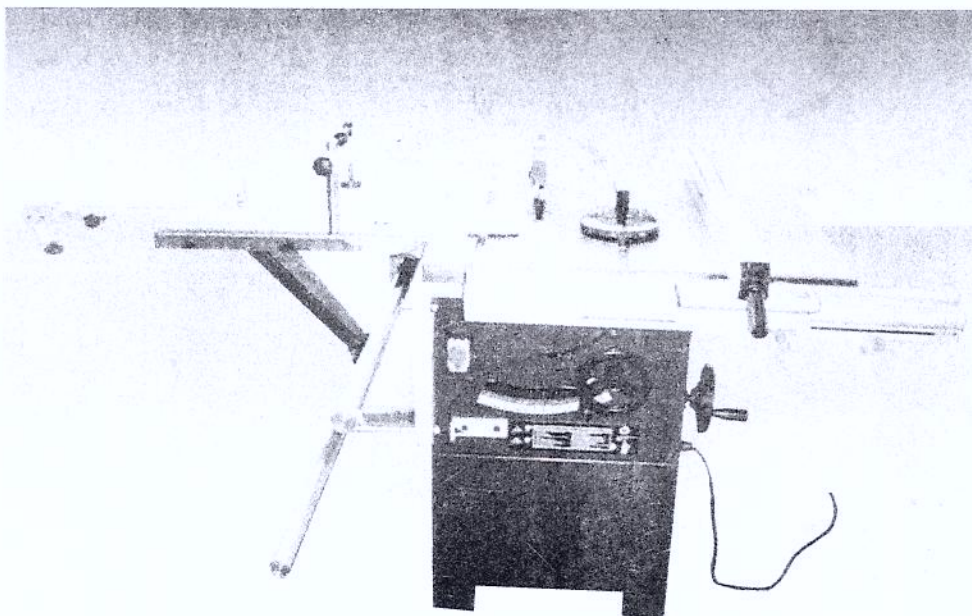

CE

TILTING ARBOR HEAVY DUTY SLIDING TABLE SAW

# Contents

1. Contents	P1
2. Please read first	P1
3. Specification	P2
4. Safety	P2
4.1 Specified conditions of use	P2
4.2 General safety instructions	P2
4.3 Symbols used throughout these instructions	P4
4.4 Safety devices	P4
5. Unpacking	P4
6. Special product features	P4
7. Operation elements	P4
8. Initial operation	P5
8.1 Replacing the fuse in the switch box	P5
8.2 Installing the extension table	P6
8.3 Installing the front rail	P6
8.4 Installing the rear rail	P7
8.5 Installing the long and short rail	P7
8.6 Installing the sliding table	P8
8.7 Aligning sliding table	P8
8.8 Installing the lateral fence	P9
8.9 Installing the rip fence	P9
8.10 Installing blade guard	P10
8.11 Connection of dust collector	P10
8.12 Mains connection	P10
9. Operation	P10
9.1 Sawing	P11
9.2 Mitre cuts	P11
9.3 Rip cuts with rip fence	P11
10. Care and maintenance	P12
10.1 Saw blade change	P12
10.2 Cleaning the saw	P13
10.3 Machine storage	P13
10.4 Maintenance	P13
11. Tips and tricks	P13
12. Repairs	P13
13. Trouble shooting	P14
14. transportation	P16
15. Circuit diagrams	P16
16. Instruction for thermo cutout in motor	P16
17. Diagrams and parts lists	P17

## 2. Please Read First

**WARNING!** When using electric tools basic safety precautions should always be followed to reduce the risk of fire, electric shock and personal injury including the following.

- Read these instructions before attempting to operate this product and save these Instructions.
- If you notice transport damage while unpacking, notify your supplier immediately. Do not operate the saw!
- Dispose of the packing in an environmentally friendly manner. Take to a proper collecting point.
- Keep these instructions for reference on any issues you may be uncertain about.

### ATTENTION:



**FOR YOUR OWN SAFETY: READ AND UNDERSTAND THE OWNER'S MANUAL BEFORE OPERATING MACHINE.**

1. Set up the saw on a firm, level, non-slip, vibration-free base. Keep the site free of tripping hazards. Ensure adequate lighting conditions.
2. Do not wear loose fitting clothes, remove rings, wristwatch and bracelets. Tie back long hair.
3. Wear safety goggles and face shield if operation is dusty. Wear ear defenders.
4. Do not use the saw in a moist or wet environment, or in the vicinity of combustible liquids and gases.
5. The saw must only be operated with all correctly mounted guards.
6. Never use cracked or distorted saw blades. Only use sharp saw blades.
7. Use a pushing stick when rip sawing narrow work-piece.

### Limitations on ambient conditions

The circular saw bench is designed for operating on the site:

The height above sea level doesn't exceed 1000m;

The temperature range of air doesn't exceed 0°C ~ 40°C.

### 3. Specification

Rating	380-400V~50Hz:2.2Kw	
	220-240V~50Hz:2.2Kw	
	110V~60Hz:2.2Kw	
Blade no-load speed	RPM	3500;4200
Blade tilt		0°~45°
Table dimensions	mm	560x800
Table extension	mm	305x800
Working table height	mm	860
Saw blade diameter	∅ mm	254
Blade Bore Dia.	∅ mm	25.4mm
Cutting capacity (0°)	mm	75
Cutting capacity (45°)	mm	60

### 4. Safety

#### 4.1 Specified conditions of use

This machine is intended to rip and crosscut grown timber, faced boards, chip board and wood-core plywood sheets, and similar wood-derived materials.

Do not cut round stock without suitable jigs or fixtures. The rotating saw blade could turn the work-piece. When sawing thin stock layed on edge, a suitable guide must be used for firm support.

Use of wobble saw blades is not permitted on this machine.



**Danger! Any other use is not as specified.**

Use not as specified, alteration of the electric tool or use of parts that are not approved by the equipment manufacturer can cause unforeseeable damage!

#### 4.2 General safety instructions

1. Keep work area clear
  - Cluttered areas and benches invite injuries.
2. Consider work area environment
  - Do not expose tools rain.
  - Do not use tools in damp or wet locations.
  - Keep work area well lit.
  - Do not use tools in the presence of flammable liquids of gases.

3. Guard against electric shock
  - Avoid body contact with earthed or grounded surfaces. (e.g. pipes, radiators, ranges, refrigerators).
4. Keep other persons away,
  - Do not let persons, especially children, not involved in the work touch the tool or the extension cord and keep them away from the work area.
5. Store idle tools
  - When not in use, tools should be stored in a dry locked up place. Out of reach of children.
6. **Do not force the tool**
  - **It will do the job better and safer at the rate for when it was intended.**
7. Use the right tool
  - Do not force small tools to do the job of a heavy duty tool.
  - Do not use tools for purposes not intended ; for example do not use circular saws to cut tree limbs or legs.
8. Dress properly
  - Do not wear loose clothing or jewellery, they can be caught in moving parts.
  - Non-skid footwear is recommended when working outdoors,
  - Wear protective hair covering to contain long hair.
9. Use protective equipment
  - Use safety glasses.
  - Use face or dust mask if working operations create dust.
10. Connect dust extraction equipment
  - If the tool is provided for the connection of dust extraction and collecting equipment, ensure these are connected and properly used.
11. Do not abuse the cord
  - Never yank the cord to disconnect it from the socket. Keep the cord away from heat, oil and sharp edges.
12. Secure work
  - Where possible use clamps or a vice to hold the work. It is safer than using your hand.
13. Do not overreach
  - Keep proper footing and balance at all times.

- 14. Maintain tools with care
  - Keep cutting tools sharp and clean for better and safer performance.
  - Follow instructions for lubricating and changing accessories.
  - Inspect tool cords periodically and if damaged have them repaired by an authorized service facility.
  - Inspect extension cords periodically and replace if damaged.
  - Keep handles dry, clean and free from oil and grease.
  
- 15. Disconnect tools
  - When not in use, before servicing and when changing accessories such as blades, bits and cutters, disconnect tools from the power supply.
  
- 16. Remove adjusting keys and wrenches
  - Form the habit of checking to see that keys and adjusting wrenches are removed from the tool before turning it on.
  
- 17. Avoid unintentional starting
  - Ensure switch is in "off" position when plugging in.
  
- 18. Use outdoor extension leads
  - When the tool is used outdoors, use only extension cords intended for outdoor use and so marked.
  
- 19. Stay alert
  - Watch what you are doing use common sense and do not operate the tool when you are tired.
  
- 20. Check damaged parts
  - Before further use of tool, it should be carefully checked to determine that it will operate properly and perform its intended function.
  - Check for alignment of moving parts, binding of moving parts, breakage of parts, mounting and any other conditions that may affect its operation.
  - A guard or other part that is damaged should be properly repaired or placed by an authorized service center unless otherwise indicated in this instruction manual.
  
- Have defectives switches replaced by an authorized service center.
- Do not use the tool if the switch does no turn it on and off.
  
- 21. Warning
  - The use of any accessory or attachment other than one recommended in this instruction manual may present a risk of personal injury.
  - Use push-sticks or push blocks to feed the work-piece past the saw blade.
  - Use and correct adjustment of the riving knife.
  - Use and correct adjustment of the upper saw blade guard.
  - Rebating or grooving should not be carried out unless suitable guarding, such as a tunnel guard, is fitted above the saw table.
  - Saws shall not be used for slotting (stopped groove).
  - Use only saw blades for which the maximum possible speed is not less than the maximum spindle speed of the tool and the tool and the material to be cut.
  - When transporting the machine use only transportation devices and do never use guards for handling or transportation.
  - During transportation the upper part of the saw blade should be covered; for example by the guard.
  - Do not use saw blades which are damaged or deformed.
  - Replace table insert when worn.
  - Use only saw blades recommended by the manufacturer, which conform to EN 847-1.
  - Take care that the selection of the saw blades is suitable for the material to be cut.
  - Wear respiratory protection to reduce the risk of inhalation of harmful dust.
  - Saw blades shall be carried in a holder whenever practicable;
  - Connect circular saws to a dust-collecting device when sawing wood.
  - Do not use High speed steel (HS) blades.
  - The push-stick or push block should always be stored with the machine when not in use.

22. Have your tool repaired by a qualified person

This electric tool complies with the relevant safety rules. Repairs should only be carried out by qualified persons using original spare parts, otherwise this may result in considerable danger to the user.

#### 4.3 Symbols used throughout these instructions



##### **Danger!**

Indicates risk of personal injury or severe material damage.



##### **Risk of electric shock!**

Risk of personal injury by electric shock.



##### **Drawing-in/trapping hazard!**

Risk of personal injury by body parts or clothing being drawn into the rotating saw blades.



**Caution!** Risk of material damage.



**Note:** Supplementary information.

#### 4.4 Safety devices

##### **Blade guard**

The blade guard (a) protects against unintentional contact with the saw blade and from chips flying about.

Always have blade guard installed during operation.

##### **Riving knife**

The riving knife (b) prevents the work-piece from being caught the rising teeth of the saw blade and being thrown against the operator.

Always have blade guard installed during operation.

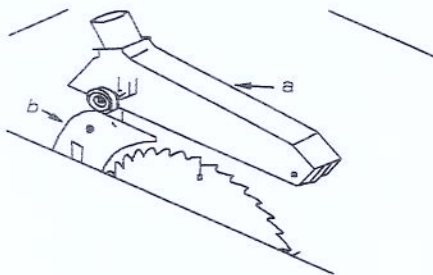

#### **Push stick**

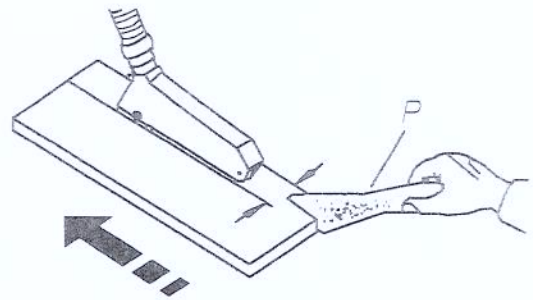

The push stick (p) serves as an extension of the hand and protects against accidental contact with the saw blade.

Use push stick if distance rip fence – saw blade is  $\leq$  120mm. In order for the push stick to be always at hand, it can be stored in a sheath inside the machine's housing.

#### **5. unpacking**

**Note:** make sure all items are accounted for before discarding any packaging material.

**Warning:** to avoid injury, if any parts are missing, do not attempt to assemble the machine, do not plug in the power cord, do not turn the switch on until missing parts are obtained and installed correctly.

#### **6. Special product features**

All operating elements are located at the machine's front. Mitre fence and rip fence are standard delivery.

#### **7. Operating elements**

##### **ON / OFF switch with emergency stop**

- To switch ON = press green button
- To switch OFF = press red button or switch cover.

### Height hand-wheel for setting the depth of cut

The depth of cut can be adjusted by turning the hand-wheel

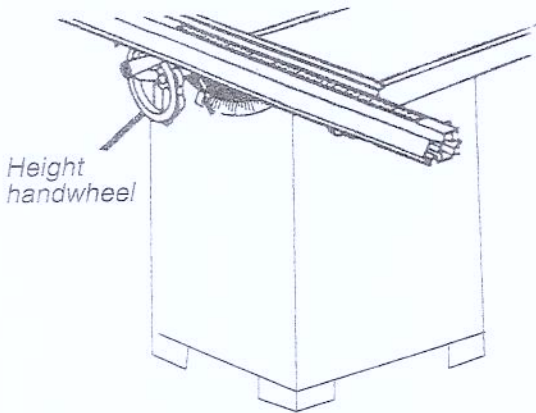

### Bevel hand-wheel for blade tilt setting

With the handwheel (d) the saw blade can be steplessly tilted to the right from 0° (vertical) through 45°.

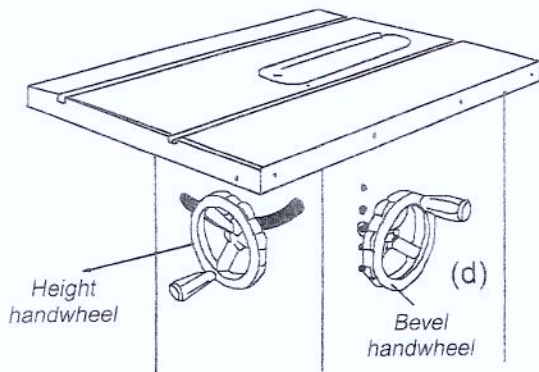

### Rip fence

The rip fence slides on the saw table's front rail and rear rail.

### Adjusting the miter gage

You can set the mitre gage at 0° and plus or minus 45° with the mitre gage stop pin and adjustable stop screws.

**Note:** the mitre gage provides close accuracy in angled cuts. For very close tolerances, test cuts are recommended.

- Loosen knob and pull out on stop pin to rotate mitre gage base past atop screws.
- Loosen the lock nut of the 0° stop screws at the stop pin with an 8 mm wrench.
- Place a 90° square against the mitre gage rod and the mitre gage base.

- If the rod is not square, loosen the knob, adjust the rod, and tighten the knob.
- Adjust the 0° stop screw until it rests against the stop pin.
- Adjust the plus and minus 45° stop screws using a 45° triangle and the steps above.

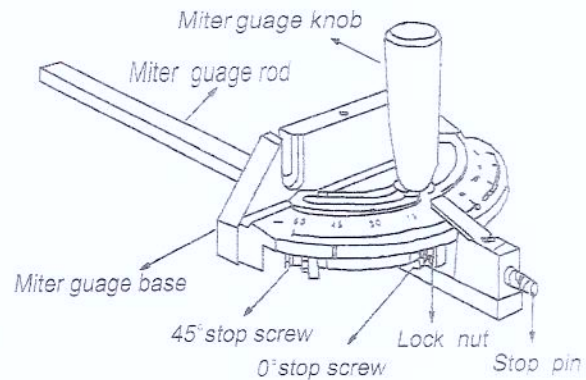

## 8. Initial Operation



### Caution:

Before changing the fuse, you must make sure the power cable be unplugged in order to avoid injury.

### 8.1 Assembling the box stand

Unpacking the master carton, take off the plastic foam and find four pieces stand panels, four stand level feet and a bag of hardware.



### Note:

Remaining hardware from this bag is used for assembly box stand.

Use 8-M8x12 hexagon head bolt with 16- $\varnothing$  8 washer, 8-M8 nut tighten the front panel and side panel, then tighten the rear panel and side panel.

Place 4-stand level foot on the down side of stand, then also use 8-M8x12 hexagon head bolt with 16- $\varnothing$  8 washer, 8-M8 nut tighten the stand and level foot.

 **Warning:**

Do not lift the saw until without help.  
The saw table is too heavy to lift without help,customer should seek assistance from staff to lift this item.

### 8.2 Installing the extension table

 **Warning:**

Installing the extension table needs another man 's help.

1. Take off the extension table from the major case,put 4-M8×20 hex head screws with 4-8mm washer in the holes of the right major table and extension table,so the screw heads extend outward 10mm.

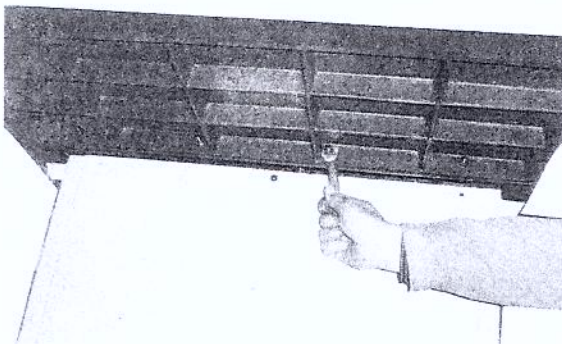

2. Lift the extension table slightly and sure four screws up on holes of major table.
- 3.Center the extension table over the edges and tap it,check the surface alignment.
- 4.Tighten 4-screws with a 12mm wrench.

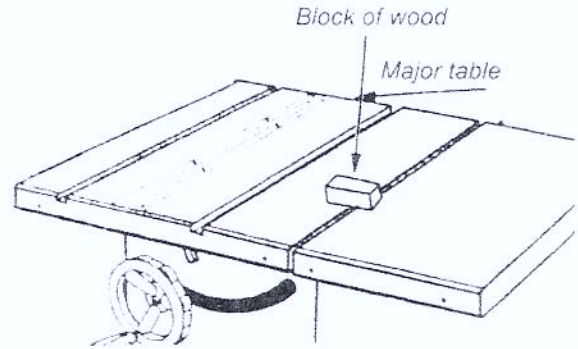
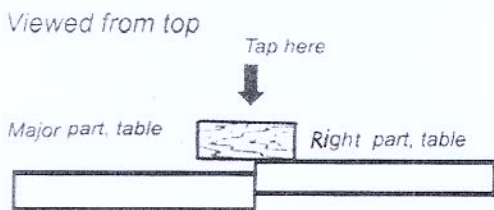
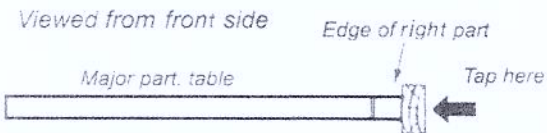

### 8.3 Installing the front rail

 **Warning:**

The front and rear rails must be carefully aligned to reduce the risk of kickback,which can cause serious injury.

From the only carton take out the front rail with a plastic bag in which you can find the following parts be used on front rail.

Right and left end cap

6-tapping screw ST3.9×12

Locate the following hardware from a hardware bag in the major case:

4-square head bolt M8×25

4-8mm flat washer

4-M8 hex nuts

1. Insert the 4 square head bolts into the table and extension,so the bolt heads extend out 6mm.
2. Loosely attach a flat washer and a hex nut to each bolt.
3. Slide the slot on the front rail over bolts,adjust each bolt to fit the rail closely to the table.
4. push the front rail against table and hand tighten each hex nut.

 **Note:**

Make sure there are no gaps between the rail and edge of the table or extension.

- Put the left end cap on the rail end, insert the tapping screw and tighten with phillips screwdriver.

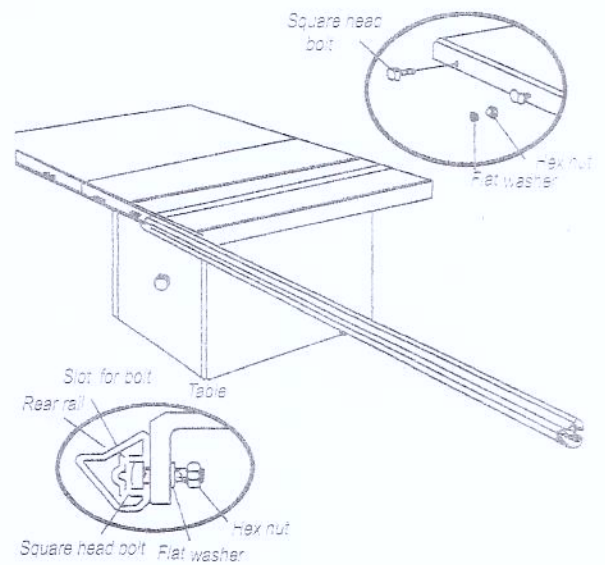
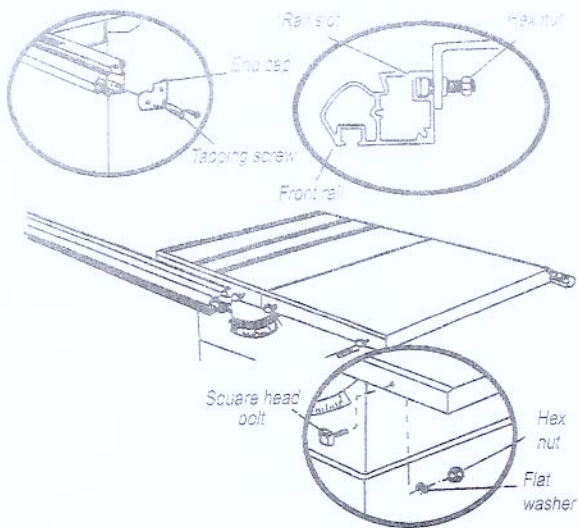

Note:

Make sure there are no gaps between the rail and edge of table or extension.

#### 8.4 Installing the rear rail

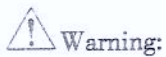

Warning:

The front and rear rails must be carefully aligned to reduce the risk of kickback, which can cause serious injury.

Take out the rear rail from carton.

Locate the following hardware from a hardware bag in the major case:

- 4-square head bolt M8×25
- 4-8mm flat washer
- 4-M8 hex nuts

- At the back of the table put the square head bolts in the holes in the edge of the table and extension so the bolt heads extend outward 6mm.
- Loosely attach the flat washer and hex nut onto bolts, slide the slot on the rear rail over bolts, adjust each bolt to fit the rail closely to the table.
- Push the rear rail against table and tighten all screws.

#### 8.5 Installing the long and short rail

Take out the plastic bag from the major case, in this bag you can find the following parts will be used for installing the long and short rails.

- 2-supporting and connection plate of rail(F52)
- 4-flat washer 8(F04)
- 4-hex head screw M8×18(F60)
- 1-brace accessory(F53,54,55,56)
- 2-adjustable link pole(F02)
- 2-short guide axle(F06)
- 2-long guide axle(F07)
- 4-hex socket cap head screw M8×35(F08)
- 4-spring washer 12(F73)
- 4-flat washer 12(F74)
- 4-hexagon nut M12(F75)

Locate long rail and short rail from the accessory case.

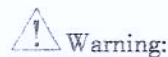

Warning:

The long rail and short rail must be carefully aligned to

reduce the risk of kickback, which can cause serious injury.

1. There are two holes on each guide holder, first put one adjusting link pole against the guide holder and align the holes on the adjusting link pole with the holes on the guide holder. insert one short guide axle. add one flat washer 12, spring washer 12 and hex nut M12 and hand tighten. repeat the above steps to install the lower hole use one long guide axle. repeat for another adjusting link pole.
2. Lift the long rail slightly and keep the holes on it align with the holes on the two short guide axles. insert two hex socket cap head screw M8×35 and hand tighten.
3. lift the short rail slightly and keep the holes on it align with the holes on the two long guide axles. insert two hex socket cap head screw M8×35 and hand tighten.
4. when the slide table slides smoothly without any resistance over the long and short rails. tighten all the screws with proper wrench.

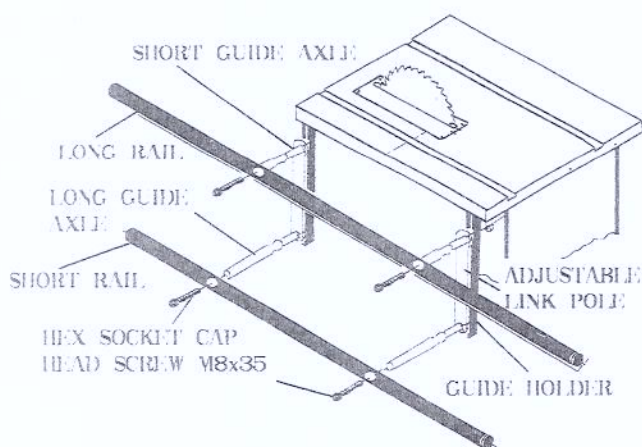

### 8.6 Installing the sliding table

Take out this accessory from the major case

 **Warning :**

Do not lift the sliding table without help.

The sliding table accessory is too heavy to lift without

help, customer should seek assistance from staff to lift this item.

1. Lift the sliding table slightly, the sliding table has three bearing parts, slide the two upper parts over the long rail and the lower one bearing part over the short rail.

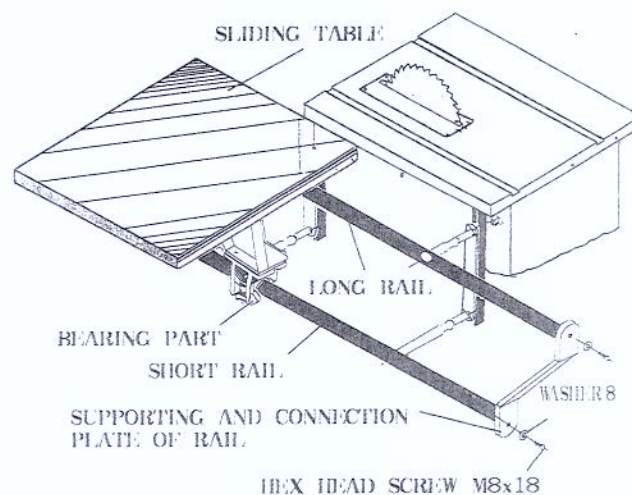

2. In front end of the rails take one supporting and connection plate of rail and put it against the long and short rail, align the holes on the plate with the holes on the long and short rail ends. Match two flat washer 8. Insert two hex head screw M8×18 in both holes and tighten by wrench.

3. At the back end of the long and short rails. repeat the above steps for the upper hole of another supporting and connection plate of rail, lift the brace accessory, align the three holes on the brace tube (F53) and supporting and connection plate of rail and short rail. put a hex head screw M8×18 and a flat washer 8 into the holes and tighten.

### 8.7 Aligning sliding table

1. Stand at the front of the saw and line up the front edges of the table and sliding table. if the sliding table's surface is lower or higher than the major table's surface, you can adjust it by one set adjustable bolts under the guide holder, first loosen 4 hex nut M12 (F75) and hex nut M8 (F05). tighten or loosen the two bolts M8×35 (F08), do this can make the long and short rails up and down, till adjust the sliding table to the proper position, tighten the 2 hex nuts M8 and the 4 hex nut M12.

1. If the right and left edges of the sliding table aren't in

the same level position, loosen the two hex socket cap head screws M8×18 (F09) slightly, adjust the two bolts M8×40(F58) to have the two supporting blocks remove, and this can have the sliding table's left side up and down, after adjustment, lock all the screws by wrench.

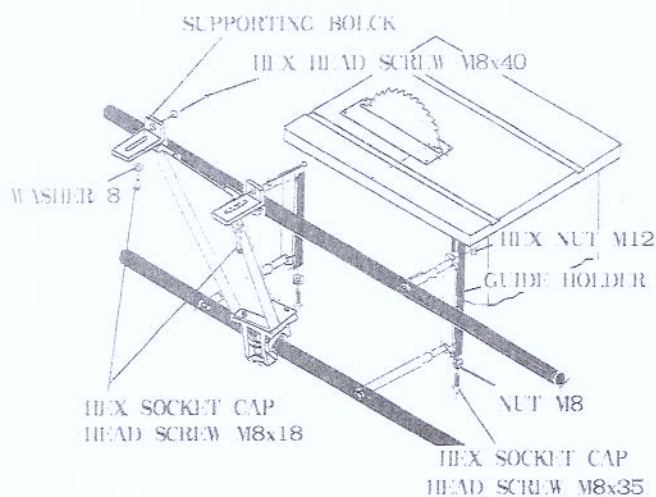

### 8.8 Installing the lateral fence

Take out the lateral fence from the only carton



**Warning:**

The lateral fence must be carefully aligned to reduce the risk of kickback, which can cause serious injury.

1. Before installing this part, make sure the distance between the right edge of protection board (F36) and lateral fence (F23) is 29mm; if not, loosen the two cross-recessed countersunk head screws M8×18 in the bottom of protection board and remove protection board to the proper position, tighten the two screws.
2. Loosen 2-M8×10 slotted set screws (F33) in the bottom of lateral fence slightly, place the lateral fence on the sliding table and insert the core axle for lateral fence (F32) in the right hole close to vertical pole (F31). Adjust the distance from the right edge of lateral fence to the left edge of saw blade by removing the lateral fence; the exact distance should be 30mm; this can guarantee the workpiece's width being cutted agree with the scale (F28) on the lateral fence.

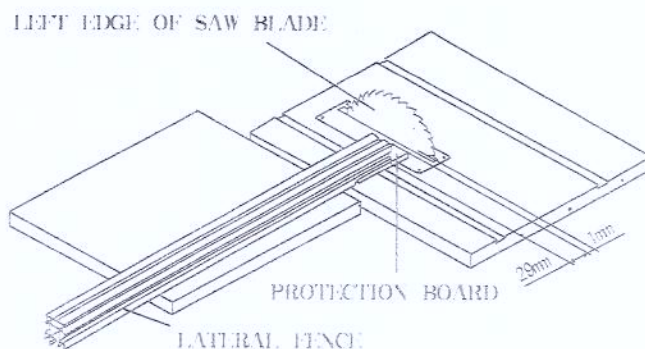

### 8.9 Installing the rip fence

1. Unpacking the rip fence part from fence carton.
2. Place the rip fence assembly on the scale mount.
3. If need, attach the "L" shape extension to the rip fence.
4. Slide the rip fence onto the rear and front rails.



**Caution**

This fence has a set micro adjusting device, which be positioned on the right side of the scale indicator housing when you sure the exact position by adjusting the rip fence and micro device, you should push down the rip fence handle to lock the rip fence.

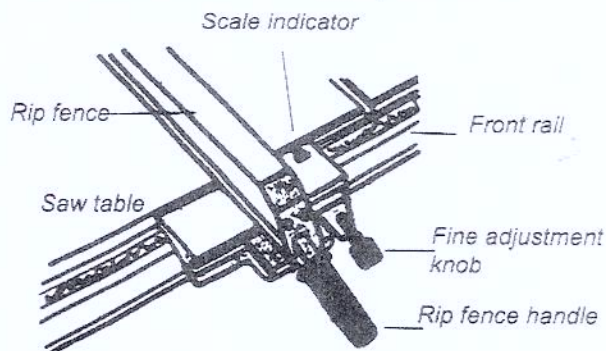

5. Adjust the rear and front rails to keep the rip fence 1mm above the table.
6. Place the rip fence against the saw blade, check the red line of scale mount right lens with the scale "0" on the front rail.
7. Lock down the rip fence handle after adjusting the rip fence to the proper position.

### 8.10 Installing blade guard

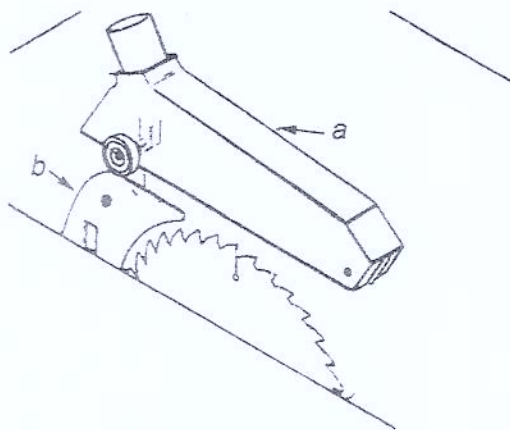

Installing blade guard (a) on riving knife (b).

### Riving knife information

<p>Thickness: 2.8mm          Blade Diameter: 254mm          Slot Width: 8.2mm</p>
---

### 8.11 Connection of dust collector

 **Danger!**

Dust of certain timber species (e.g. beech, oak, ash) can cause cancer when inhaled. Use a suitable dust collector when working in enclosed spaces, the dust collector must meet the following requirements:

- Hoses must fit the outer diameter of the dust extraction ports (blade guard 30mm and the chip case 100mm)
- Air flow volume  $\geq 460\text{m}^3/\text{h}$ ;
- Volume at dust extraction port of saw:  $\geq 530\text{Pa}$
- Air speed at dust extraction port of saw:  $\geq 20\text{m/s}$ ;

Operation without a dust collector is only possible:

- outdoors;
- for short-term operation;  
(up to a maximum of 30 minutes)
- with dust respirator.

### 8.12 Mains connection

 **Danger! Electrical Hazard**

Operate saw in dry environment only.

Operate saw only on a power source matching the following requirements:

- mains voltage and system frequency conform to the voltage and frequency shown on the saw's name plate;
  - outlets properly installed, earthed and tested.
- Position power supply cable so it does not interfere with the work and is not damaged. Protect power supply cable from heat, aggressive liquids and sharp edges. Do not pull on power supply cable to unplug.

### 9. Operation

 **Risk of injury!**

This saw may only be operated by one persons at a time. Other persons may stay only at a distance from the saw for the purpose of feeding or removing stock.

Before starting work check to see that the following are in proper working order:

power source range:  $230\text{V} \pm 10\%$ ,  $50\text{Hz} \pm 1\text{Hz}$

environment humidity requirement for operation:

$\leq 50\% @ 40^\circ\text{C}$  or  $90\% @ 20^\circ\text{C}$

environment humidity requirement for storage and transport:  $-25^\circ\text{C} \sim 55^\circ\text{C}$

- power cable and plug;
- ON/OFF switch;
- riving knife;
- blade guard;
- push stick;

Use personal protection gear;

- dust respirator;
- hearing protection;
- safety goggles.

Assume proper operating position;

- at the front of the saw;
- in front of the saw;
- to the left of the line of cut;
- if working with two persons the second person should stand at a rear table extension.

If the type of work requires, use the following;

- table extension if working with two persons or if otherwise work-pieces would fall off the saw table;
- dust collector.

Avoid typical operator mistakes;

- Do not attempt to stop the saw blade by pushing the work-piece against its side. Risk of kickback.
- Always hold the work-piece down on the table and do not jam it. Risk of kickback.
- Never cut several work-pieces at the same time – and also no bundles containing several individual pieces. Risk of personal injury if individual pieces are caught by the saw blade uncontrolled.



**Drawing-in/trapping hazard!**

Never cut stock to which ropes, cords, strings, cables or wires are attached or which contain such material.

## 9.1 Sawing

For cutting the work-piece is evenly fed against the saw blade towards the rear of the table:

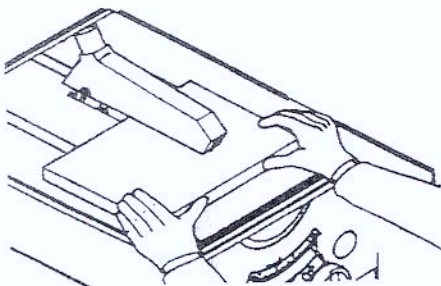

1. Set depth of cut. The blade guard must be rest with its front edge on the work-piece.
2. Set blade tilt and lock in position.
3. Mount rip fence, if required.
4. Start saw.

5. Cut work-piece in a single pass.

6. Switch machine off if no further cutting is to be done immediately afterwards.

## 9.2 Mitre cuts

1. Fit mitre fence to the table slot.

2. Loosen lock knob, set to desired angle with the indicator and tighten lock knob again.

3. Cut work-piece by pushing the mitre fence-forward.

## 9.3 Rip cuts with rip fence

1. Lock rip fence in required position on saw table.



**Danger!**

Use push stick if distance between rip fence and saw blade is less than 120mm.

Use of push block and push stick.

Push stick should be used to avoid working with hands close to the sawblade. Push blocks should be between 300mm and 400mm long, 80mm to 100mm wide and 15mm to 20mm deep. Push blocks should be used when cutting small work-piece and in circumstance where it is necessary to push the work-piece against the fence.

The information concerning maintenance and repair of push sticks, you must change the part by a new one when you are sure the push stick or push block is damaged in order to avoid being injured by the running saw blade.

2. Reposition auxiliary fence extrusion if necessary:

- Low edge (as shown) = for sawing thin stock, and with a tilted saw blade.

- High edge = for cutting thick stock (max. 65mm).

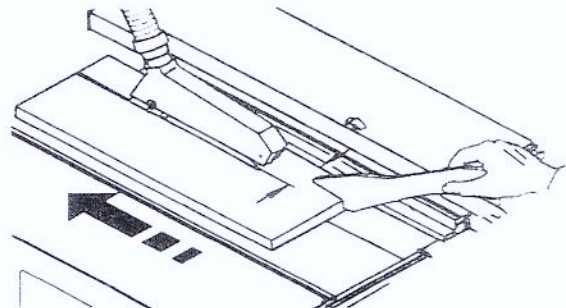

3. Set blade tilt and lock in position.

4. Start motor.

5. Cut work-piece in a single pass.

6. Switch machine off if no further cutting is to be done immediately afterwards.

## 10. Care and maintenance

### Danger!

Prior to all servicing:

- Switch machine OFF.
- Unplug power cable.
- Wait until the saw has come to a complete stop.

- Check that all safety devices are operational against after each service.
- Replace defective parts, especially of safety devices, only with genuine replacement parts. Parts not tested and approved by the equipment maker can cause unforeseen damage.
- Repair and maintenance work other than described in this section shall be only carried out by qualified specialists.

### 10.1 Saw blade change

#### Danger!

**Risk of injury by the saw blade's teeth. Wear gloves when changing blades.**

1. Remove blade guard.
2. Lower saw blade fully.
3. Loosen 6 screws on cover plates. Remove throat plates slightly.

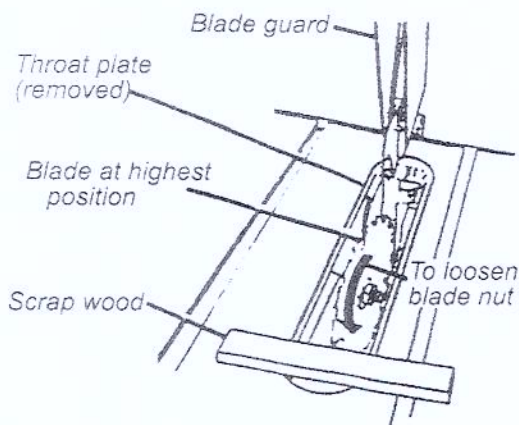

4. Raise saw blade fully.
5. To block the saw blade insert lock bar into hole in the saw table and turn saw blade by hand until lock bar engages in saw spindle hole.

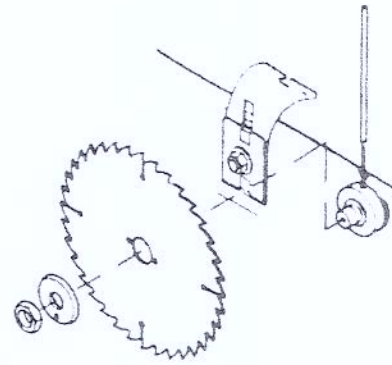

6. Loosen saw blade spindle arbor nut with spanner (L.H. thread!)
7. Take outer blade collar and saw blade off the saw spindle.
8. Clean clamping surfaces of saw spindle and saw blade.

#### Danger!

**Do not use cleaning agents (e.g. for removing resin residue) that could corrode the light metal components the saw, the stability of the saw would be adversely affected.**

9. Put on a fresh saw blade.

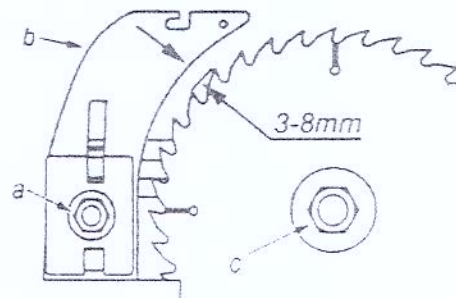

#### Danger!

**Use only suitable saw blades - when using unsuitable damaged blades parts could be explosive like hurled from it by the centrifugal force.**

#### **Do not use:**

- saw blades with visible damage;
- cut-off wheel blades.

10. Slide outer blade collar onto saw spindle.
11. Screw arbor nut, with the low side facing the blade, onto the saw spindle (L.H. thread)

 **Danger!**

- Do not extend the arbor nut wrench.
- Do not tighten arbor nut by tapping on the wrench.
- After tightening the arbor nut do not forget remove the saw spindle lock bar!
- Fixing of saw blade to spindle.
- When the spindle diameter is less than the saw blade bore diameter, flanged bushes provided by the machine manufacturer should be used to make up the difference. The use of loose rings or bushes is not permitted.

11. Loosen screw (a) of the riving knife bracket.

12. Adjust the distance between the saw blade's outer edge and the riving knife (b). It must be 3-8mm.

13. Reinstall the throat plate and blade guard.

Slot for the saw blade in the table.

The total width of the slot for the saw blade is 12mm, the tilting direction is opposite to the ordinary item, so the distance between the fixed saw flange and the edge of the table slot is 8mm.

Selection of saw blade and riving knife.

The range of saw blade diameters and thickness is below:

Saw blade diameter: 254mm

Saw blade thickness: 3mm

The operator should only select saw blade of a diameter and thickness suitable for the machine, as specified in the instruction handbook.

Selection of the riving knife is dependent on the saw blade thickness and saw blade diameter. The operator should ensure that the riving knife selected is suitable for the saw blade being used.

The riving knife-guiding slot should be no more than 0.5mm wider than the riving knife guiding elements.

### 10.2 Cleaning the saw

1. Lay machine on its side.
2. Remove chips and saw dust with vacuum cleaner or brush:
  - from saw blade setting guide elements
  - from traveling sizing table guide elements
  - from motor vent slots

### 10.3 Machine storage

 **Danger!**

**Store saw so that**

- it can not be started by unauthorized persons
- nobody can get hurt.



**Caution!**

**Do not store saw unprotected outdoors or in damp environment.**

### 10.4 Maintenance

**Before switching on**

Visual check if distance saw blade- riving knife is 3-8mm. Visual check of power cable and power cable plug for damage; if necessary have damage parts replaced by a qualified electrician.

## 11. Tips and Tricks

- Before cutting a work-piece to size make trial cuts with pieces of scrap.
- Always place a work-piece on the saw table in such way that it can not tilt or rock (e.g. always place a curved board on the table with the convex side up).
- When working long stock use suitable supports, such as table rear or side extensions (optional accessories)
- **Keep surfaces of saw table and saw base clean - in particular, remove resin residue with a suitable cleaning and maintenance spray.**

## 12. Repairs



**Danger!**

**Repairs to electric tools must be carried out by qualified electricians only!**

Electric tools in need of repair can be sent to the service centre of your country.

Refer to the spare parts list for the address.

Please attach a description of the fault to the electric tool.

### 13. Trouble Shooting



Before carrying out any fault service or maintenance work always:

1. switch machine OFF
2. unplug power cable
3. wait for saw table to come to standstill.

<b>Trouble Shooting Guide, (cont.)</b>		
Problem	Cause	Solution
Motor is slow or weak	Voltage from source is low. Windings are burned out or open. Power Switch is defective. Circuit is overloaded with appliances, lights, or other electrically powered equipment.	Request a voltage check from local power company. Have the Motor checked / repaired. Have the Power Switch replaced. Do not use other appliances or electrically powered equipment on the same circuit when using the Table Saw.
Motor overheats.	Motor is overloaded. Dull 10" saw blade. Sawdust inside table saw is blocking airflow.	Request a voltage check from the local power company. Replace the 10" saw blade. Clean out the saw base.
When ripping, the cut burns the work-piece, or stalls the motor.	10" saw blade teeth are dull. Work-piece is warped. Rip fence is not parallel with the 10" saw blade.	Sharpen or replace the 10" saw blade. Replace the work-piece. Realign rip fence, and lock it in position with the Rip Fence Handle.
Miter-gauge does not move freely.  Rip Fence does not move smoothly.	Miter gauge assembly is dirty.  Rip Fence is mounted incorrectly.	Loosen the miter gauge knob, clean and lubricate the Miter Gauge Rod.  Remove, reposition Rip Fence, and lock it in position with the Rip Fence Handle.
Bevel & Height Handles are hard to turn.	Sawdust has collected on the mechanisms inside the base.	Clean and lubricate the mechanisms inside the base.
10" saw blade does not lower when turning the Height Handle.	Bevel Lock Handle is not fully released.	Fully release the Bevel Lock Handle.
Table saw vibrates excessively.	Floor surface is uneven. V-belt is damaged. 10" saw blade is damaged. Loose bolt, Screws, Nuts.	Readjust the Leveling Feet. Replace the V-belt. Replace the 10" Saw Blade. Tighten all Hardware.

## Trouble Shooting Guide

Problem	Cause	Solution
Table saw does not start.	Motor Cord is not plugged in. Circuit fuse is blown. Circuit breaker is tripped. Motor Cord or Switch is damaged.	Plug in Motor Cord to volt electrical outlet. Replace circuit fuse. Reset circuit breaker. Have the Motor Cord or Switch replaced.
Power Switch does not operate.	Power Switch contacts are burned out. Capacitor is defective. Wiring connections are loose or damaged.	Have the Power Switch replaced. Request a voltage check from the local power company. Have the Capacitor replaced. Have the wiring connections checked / repaired.
Fuses or circuit breakers open frequently.	Motor is overloaded. Fuses or circuit breakers are wrong size or defective. Dull 10" saw blade. Power Switch is defective.	Feed work-piece more slowly. Replace fuses or circuit breakers. Replace the 10' saw blade. Have the Power Switch replaced.
Motor stalls, blows fuses, or trips circuit breakers.	Motor is overloaded. Dull 10" Saw Blade. Fuses or circuit breakers are wrong size or defective. Feeding work-piece too rapidly.	Request a voltage check from the local power company. Replace the 10" saw blade. Replace fuses or circuit breakers. Feed work-piece into 10" Saw Blade more slowly.
Table Saw is noisy when running.	Motor is loose or defective.	Have the Motor checked/repaired

**Warning: To prevent personal injury and/or damage to the table saw, maintenance and repairs should be done only by a qualified technician.**

#### 14. Transportation

If you want to transport this machine to other district, you must take apart all the part that you have installed. If possible use original carton for shipping.

#### 15. Circuit diagrams

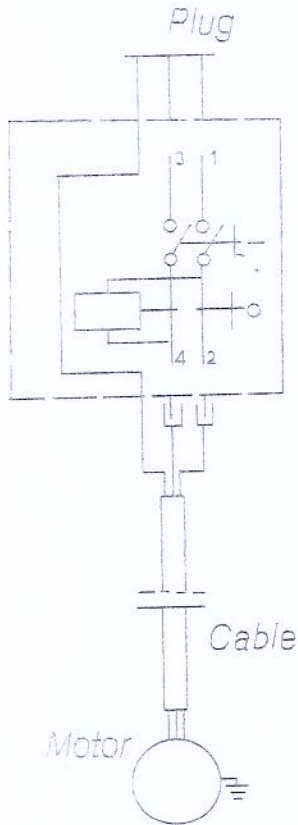

#### 16. Instruction for thermo cutout in motor

There is thermo cutout inside the motor, this device protect motor from being damaged in high temperature's condition. When the motor's temperature is too high the fuse will shut off automatically; you should check the reasons to cause the high temperature or be carried out by qualified specialists at once. The thermo cutout will return to normal automatically once the temperature low down.

The end user shall provide a 10A over-current protection device in supply system for this machine.

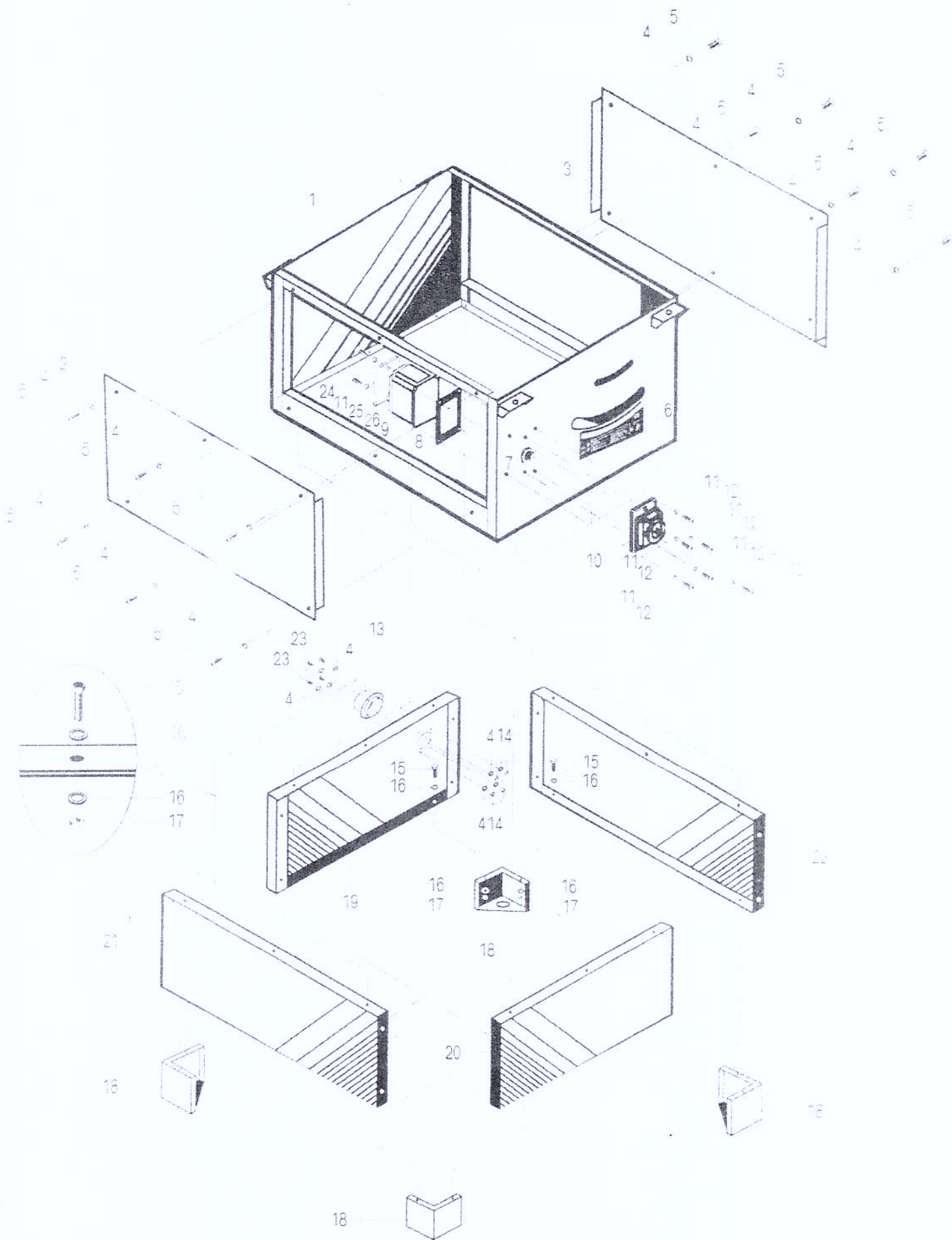
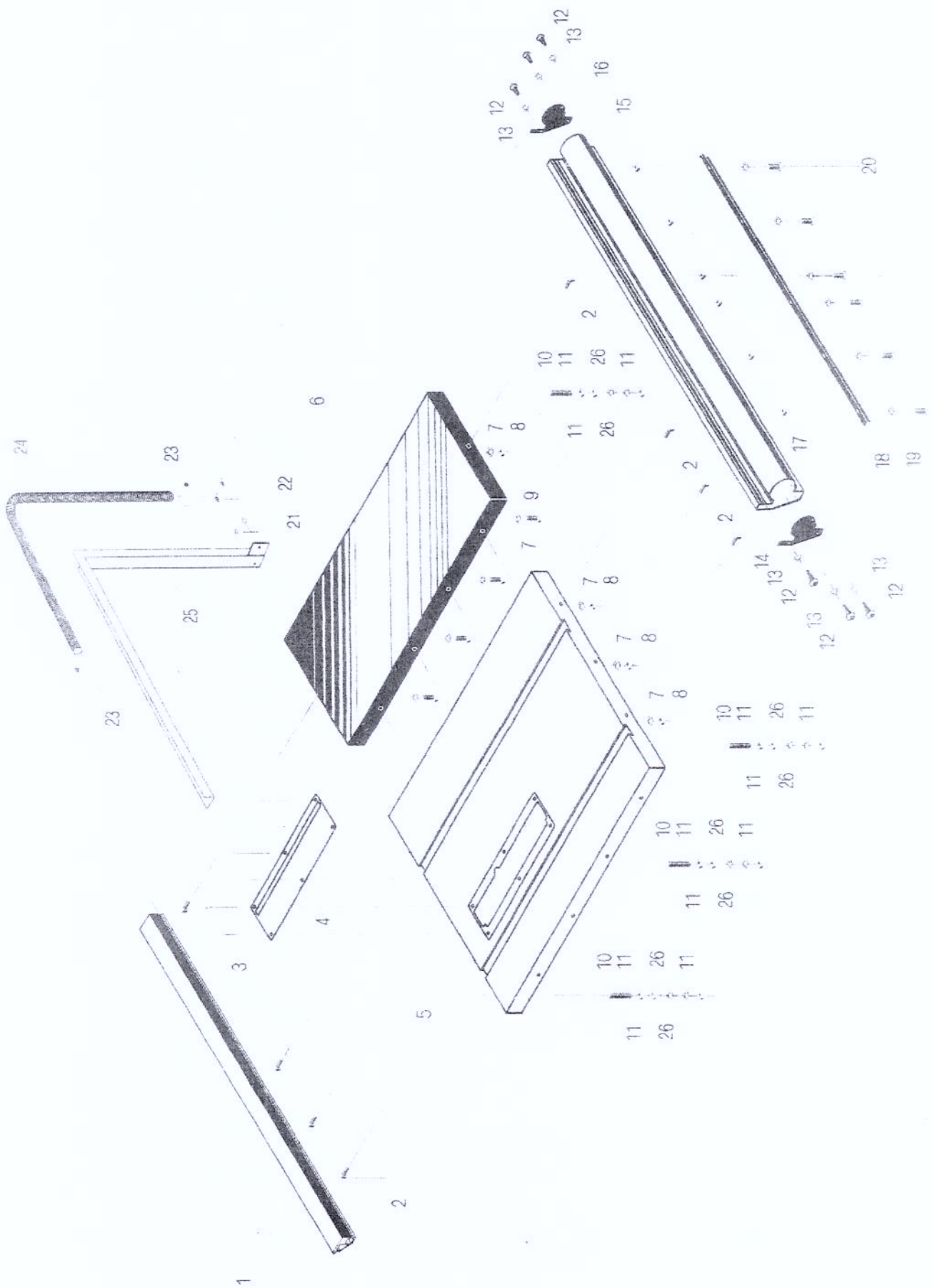

DIAGRAM A

NO	DESCRIPTION	QTY
A-01	Base	1
A-02	Left side panel for base	1
A-03	Right side panel for base	1
A-04	Flat washer 6	20
A-05	Cross recessed pan head screws M6 X 10	12
A-06	Graduated plate	1
A-07	Cable-grand	1
A-08	Rubber washer of switch box	1
A-09	Switch box	1
A-10	Switch	1
A-11	Flat washer 6	8
A-12	Cross recessed pan head screws M4 X 10	6
A-13	Dust collect tube joint	1
A-14	Hexagon nut M 6	4
A-15	Hexagon head bolt M8 X 12	2 8
A-16	Flat washer 8	5 6
A-17	Hexagon nut M 8	2 8
A-18	Stand level foot	4
A-19	Front panel for stand	1
A-20	Rear panel for stand	1
A-21	Left side panel for stand	1
A-22	Right side panel for stand	1
A-23	Cross recessed pan head screws M 6 X 16	4
A-24	Cross recessed pan head tapping screws ST 4.0 X 12	2
A-25	Switch bottom plate	1
A-26	Bottom plate rubber washer	1



NO	DESCRIPTION	QTY
B-0 1	Rear rail	1
B-0 2	Square head bolt M8 X 25	8
B-0 3	Cross recessed countersunk head screws M5 X 6	5
B-0 4	Cover plate	1
B-0 5	Work table	1
B-0 6	Extension table	1
B-0 7	Flat washer 8	12
B-0 8	Hexagon nut M 8	8
B-0 9	Hexagon head bolt M8 X 20	4
B-1 0	Slotted set screw with flat point M10 X 80	4
B-1 1	Hexagon nut M10	12
B-1 2	Cross recessed pan head tapping screw ST4.0 X 12	6
B-1 3	Flat washer 4	6
B-1 4	Left end cap for front rail	1
B-1 5	Front rail	1
B-1 6	Right end cap for front rail	1
B-1 7	Square nut M5	6
B-1 8	Rack	2
B-1 9	Lock washers external teeth	6
B-2 0	Cross recessed pan head screw M5 X 8	6
B-2 1	Flat washer 6	2
B-2 2	Hexagon socket cap screw M 6 X 15	2
B-2 3	Neck chain	2
B-2 4	Dust collect tube	1
B-2 5	Dust collect frame	1

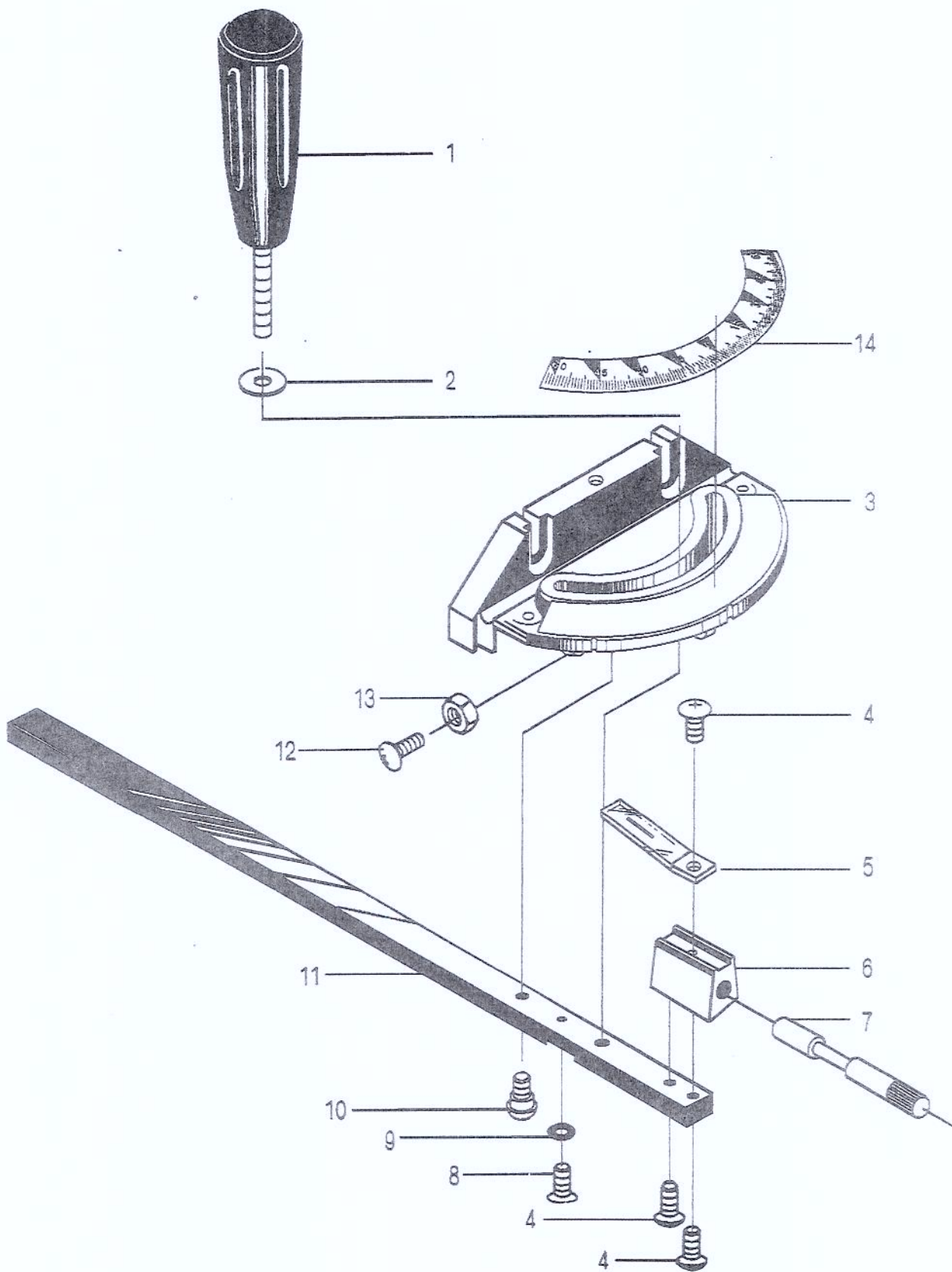

DIAGRAM C

NO	DESCRIPTION	QTY
C-0 1	Locking handle for graduated disc	1
C-0 2	Flat washer 8	1
C-0 3	Miter gauge	1
C-0 4	Cross recessed pan head screw M5 X 10	3
C-0 5	Miter gauge indicator	1
C-0 6	Miter gauge block	1
C-0 7	Stop pin	1
C-0 8	Cross recessed countersunk head screw M5 X 8	1
C-0 9	Miter gauge rod washer	1
C-1 0	Shoulder screw	1
C-1 1	Miter gauge guide rod	1
C-1 2	Cross recessed pan head screw M4 X 8	3
C-1 3	Hexagon nut M4	3

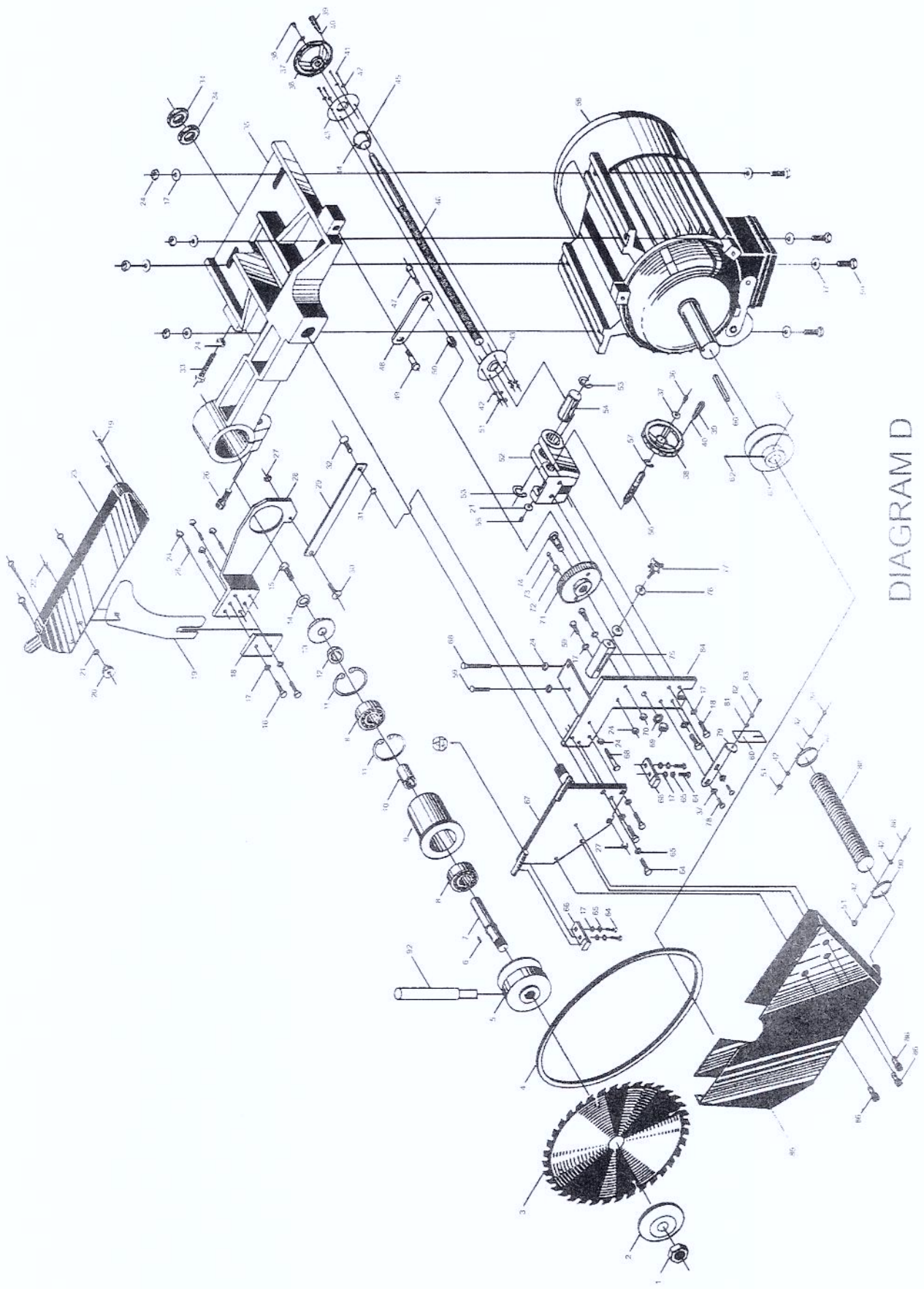

DIAGRAM D

NO	DESCRIPTION	QTY	NO	DESCRIPTION	QTY
D-01	Blade nut M16(left hand)	1	D-39	HANDLE	2
D-02	Outer blade washer	1	D-40	Handle bolt	2
D-03	Blade	1	D-41	Cross recessed pan head screw M6x16	4
D-04	A-belt	1			
D-05	Pulley	1	D-42	Flat washer 6	8
D-06	Key A-type	1	D-43	Ball bracket	2
D-07	Arbor shaft	1	D-44	Thread rod ball	1
D-08	Bearing 80203	2	D-45	Spring dowel 4x28	1
D-09	Arbor shaft sleeve	1	D-46	Adjusting thread rod	1
D-10	Arbor shaft bush	1	D-47	Worm-wheel connecting rod nail A	1
D-11	Circlips for hole D=40	2	D-48	Worm-wheel connecting rod	1
D-12	Arbor shaft end bush	1	D-49	Worm-wheel connecting rod nail B	1
D-13	Press washer	1	D-50	Connecting rod bush	1
D-14	Single coil spring lock washer 6	1	D-51	Hexagon nut M6	4
D-15	Hexagon head bolt M6x16	1	D-52	Adjusting frame	1
D-16	Hexagon head bolt M8x20	2	D-53	Circlips for shaft D=24	2
D-17	Flat washer 8	18	D-54	Knuckle	1
D-18	Press board for riving knife	1	D-55	Hexagon socket cap head screw M6x12	1
D-19	Riving knife	1			
D-20	Flower nut	1	D-56	Height adjustment rod	1
D-21	Large washer 6	2	D-57	Circlips for shaft D=18	1
D-22	Step bolt M6x46	1	D-58	Motor	1
D-23	Blade guard	1	D-59	Hexagon head bolt M8x40	7
D-24	Hexagon nut M8	13	D-60	Key 8x7x50	1
D-25	Hexagon socket set screw with flat point M8x25	4	D-61	Hexagon socket set screw with flat point M6x9	1
D-26	Hexagon socket cap head screw M10x30	1	D-62	Hexagon socket set screw with flat point M6x6	1
D-27	Locking nut with plastic insert M8	2	D-63	Motor wheel	1
D-28	Riving Knife bracket	1	D-64	Hexagon socket cap head screw M8x24	7
D-29	Connecting rod	1			
D-30	Cross recessed countersunk head screw M8x20	1	D-65	Single coil spring lock washer 8	7
			D-66	Rotation press block	2
D-31	Connecting rod bush	1	D-67	Adjusting cradle	1
D-32	Cross recessed countersunk head screw M8x30	1	D-68	Hexagon head bolt M8x75	1
			D-69	Hexagon nut M12	1
D-33	Hexagon head bolt M8x65	1	D-70	Single coil spring lock washer 12	1
D-34	Locking nut for motor base	2	D-71	Worm-wheel	1
D-35	Motor base	1	D-72	Eccentric sleeve	1
D-36	Hexagon socket cap head screw M5x12	2	D-73	Hexagon socket cap head screw M8x30	1
D-37	Large washer 5	4	D-74	Worm-wheel shaft nail	1
D-38	Hand wheel	2	D-75	Locking block	1

NO	DESCRIPTION	QTY	NO	DESCRIPTION	QTY
D-76	Large washer 8	2	D-85	Dust collecting cover	1
D-77	Flower bolt	1	D-86	Hexagon socket cap head screw M6x18	3
D-78	Cross recessed pan head screw M5x12	2			
D-79	Point bracket	1	D-87	Neck chain	1
D-80	Point	1	D-88	Hexagon head bolt M6x25	2
D-81	Flat washer 4	1	D-89	Dust collecting tube	1
D-82	Single coil spring lock washer 4	1	D-90	Elliptic neck chain	1
D-83	Cross recessed pan head screw M4x10	1	D-91	Cross recessed countersunk head tapping screw ST4.0x26	5
D-84	Adjusting worm-wheel bracket	1			
			D-92	Spanner shaft	1

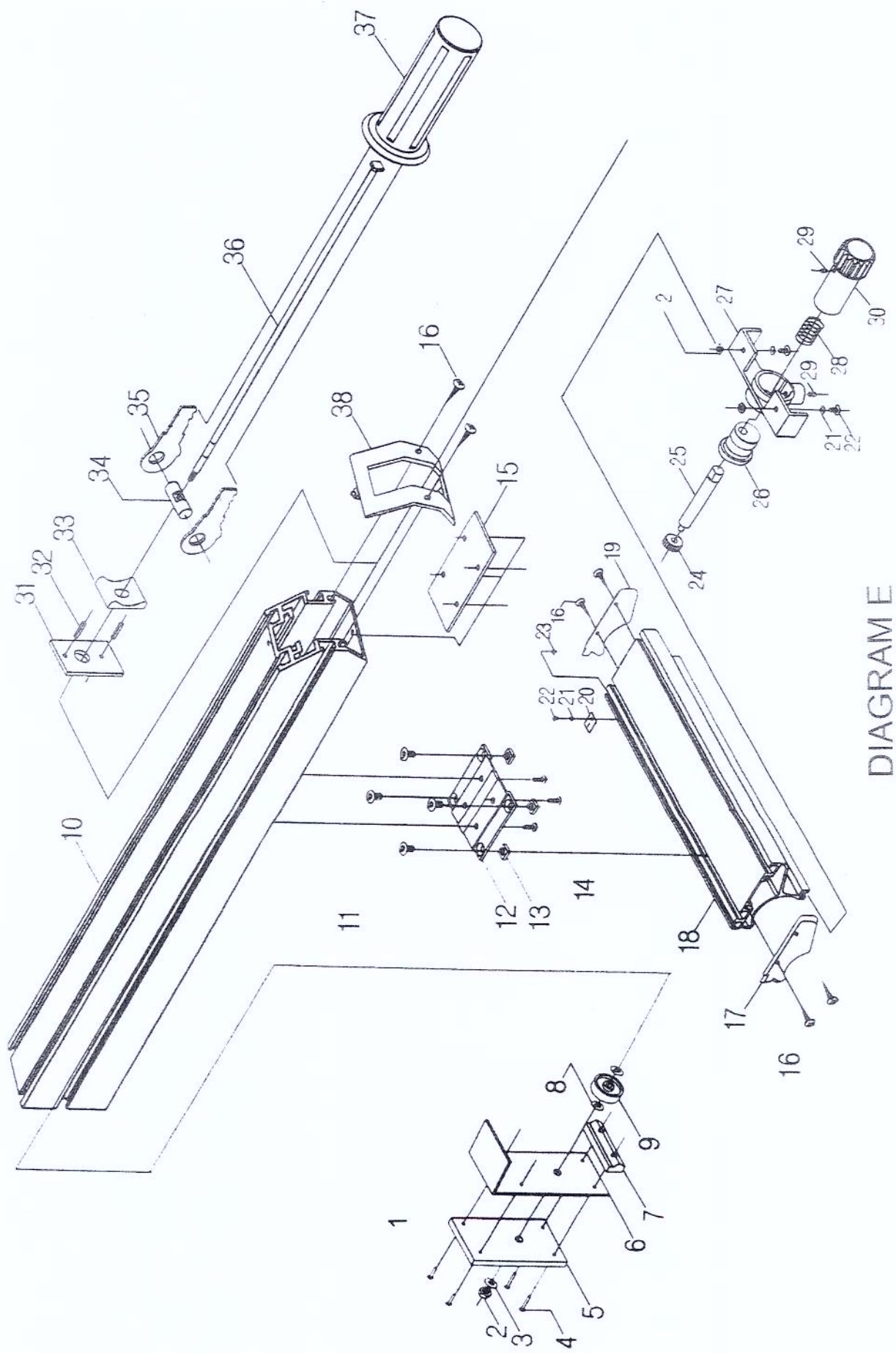

DIAGRAM E

NO	DESCRIPTION	QTY
E-01	Round head rivets with small head $\Phi 3 \times 7$	2
E-02	Hexagon nut M8	1
E-03	Flat washer 8	1
E-04	Round head rivets with small head $\Phi 3 \times 13$	2
E-05	Lock plate	1
E-06	Lock spring	1
E-07	Lock block	1
E-08	Spring ring D6	2
E-09	Rolling wheel	1
E-10	Rip fence	1
E-11	Cross recessed countersunk head screw M6x12	4
E-12	Fence plate	1
E-13	Square nut M6	4
E-14	Cross recessed pan head screw M6x16	4
E-15	Board instead of nut	1
E-16	Cross recessed countersunk head tapping screw ST4.0x12	6
E-17	Left end cap for scale indicator housing	1
E-18	Scale indicator housing	1
E-19	Right end cap for scale indicator housing	1
E-20	Scale indicator	1
E-21	Lock washer external teeth 5	3
E-22	Cross recessed pan head screw M5x10	3
E-23	Square nut	3
E-24	Small gear	1
E-25	Gear rod	1
E-26	Eccentric wheel	1
E-27	Gear rod frame	1
E-28	Spring for gear rod	1
E-29	Hexagon socket set screw with flat point M6x5	2
E-30	Rip fence handle	1
E-31	Rear board	1
E-32	Pin $\Phi 5 \times 16$	2
E-33	Rear block	1
E-34	Lock eccentric rod	1
E-35	Lock eccentric	2
E-36	Rip fence lock rod	1
E-37	Rip fence handle	1
E-38	Rip fence cover	1

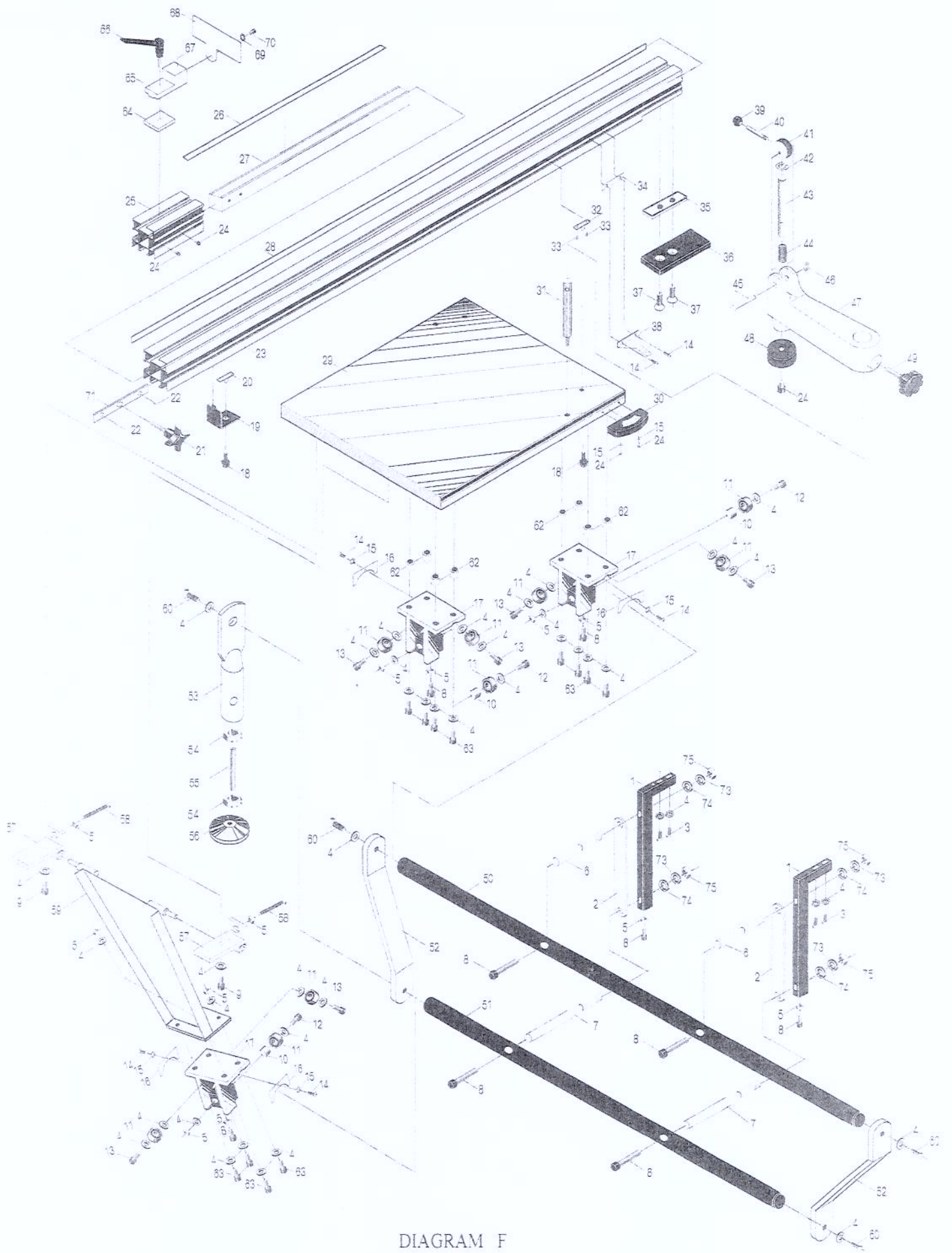

DIAGRAM F

NO.	DESCRIPTION	QTY
F-01	Guide holder	2
F-02	Adjustable link pole	2
F-03	Hex head screw M8×35	4
F-04	Flat washer 8	44
F-05	Nut M8	14
F-06	Short guide axle	2
F-07	Long guide axle	2
F-08	Hex socket cap head screw M8×35	9
F-09	Hex socket cap head screw M8×18	2
F-10	Bearing bush	3
F-11	Bearing 180018	9
F-12	Hex socket cap head screw M8×55	3
F-13	Hex socket cap head screw M8×20	6
F-14	Cross recessed pan head screw M5×10	6
F-15	Flat washer 5	6
F-16	Rubber plate	4
F-17	Bearing frame	3
F-18	Knurling screw	2
F-19	Fix board for lateral fence	1
F-20	Lozenge nut	1
F-21	Handle	1
F-22	Slotted set screw with cup point M8×8	2
F-23	Lateral fence	1
F-24	Hex socket cap head screw M5×12	5
F-25	Extension ruler frame	1
F-26	Extension ruler	1
F-27	Square pole for extension ruler	1
F-28	Lateral fence ruler	1
F-29	Sliding table	1
F-30	Mitre gauge(with scale)	1
F-31	Vertical ple	1
F-32	Core axle for lateral fence	1
F-33	Slotted set screw with cup point M8×10	2
F-34	Nut plate for pointer	1
F-35	Long narrow nut	1
F-36	Protection board	1
F-37	Cross recessed countersunk head screw M8×18	2
F-38	Pointer	1
F-39	Handle knob	1
F-40	Screw pole	1
F-41	Eccentric block	1

NO.	DESCRIPTION	Q'TY
F-42	Circlips for shaft d=14	1
F-43	Press block shaft	1
F-44	spring	1
F-45	Eccentric shaft	1
F-46	Circlips for shaft d=8	1
F-47	Clamp base	1
F-48	Clamp block	1
F-49	Knurling screw	1
F-50	Long rail	1
F-51	Short rail	1
F-52	Supporting and connection plate of rail	2
F-53	Brace tube	1
F-54	Hex nut M12	2
F-55	Screw pole	1
F-56	Support of screw pole	1
F-57	Supporting block	2
F-58	Hex head screw M8×40	2
F-59	Tilt bracket for sliding table	1
F-60	Hex head screw M8×18	4
F-62	Bearing frame sleeve	8
F-63	Hex socket cap head screw M8×32	12
F-64	Fence block nut	1
F-65	Fence block base	1
F-66	Adjustable handle screw M8×25	1
F-67	Slotted set screw with flat point M5×12	1
F-68	Fence	1
F-69	Flat washer 10	1
F-70	Hexagon socket cap head screw M10×20	1
F-71	Long strip nut	1
F-73	Spring washer 12	4
F-74	Flat washer 12	4
F-75	Hex nut M12	4